



CHAMPION • MARQUIS

ULTRACOOOL



SPECIFICATION *G*UIDE FOR COMMERCIAL MODELS

SPECIFICATION GUIDE FOR MODELS:

SAS/SAD 100

SAS/SAD 15012

AS/AD 150

SAS/SAD 10012

AS/AD 100

AS/AD 15012

SAS/SAD 150

AS/AD 10012

AS/AD/AU 20012

ADVANTAGE POINTS

1. CONSTRUCTION – Heavy gauge galvanized steel is used for cabinet panels and other load bearing components. Vacuum-formed ABS plastic water reservoirs and thick polystyrene evaporative media shields keep water from coming into contact with the steel cabinet for long-lasting durability.

2. EVAPORATIVE MEDIA – The cellulose paper of the evaporative media is treated to ensure a high water absorption rate and to resist biological degradation.

3. FINISH – All steel components (excluding the blower wheel, shaft, and pulley) are chemically treated and covered with an electrostatically-applied polyester finish at a thickness of 1 to 1.5 mil to protect the cooler from scratches and corrosion. This finish meets or exceeds requirements for the following tests:

- 1000-Hour Salt Spray Test-ASTM B117
- Abrasion Resistance Test-ASTM 4060-84
- Impact Resistance Test-ASTM D2794
- 2400-Hour Imersion Test-ASTM D870
- Adhesion Test-ASTM D3359

MODULAR CONFIGURATIONS

The unique modular design of the dual inlet side- and down-draft models are easy to reconfigure for difficult or customized installations.

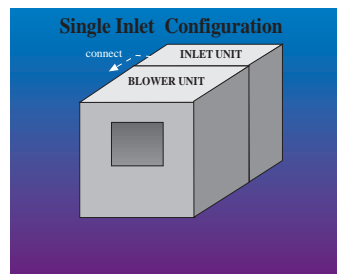
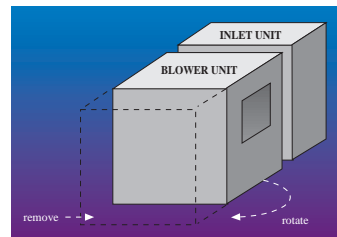
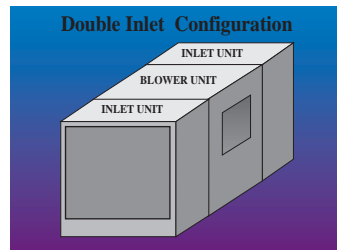

ULTRACOOOL COOLERS ARE MADE BY THE BEST: CHAMPION COOLER

One of the largest manufacturers of evaporative coolers, Champion Cooler has produced evaporative coolers that deliver high performance results and long-lasting durability for over 40 years. Champion's engineering, design, and production efforts are directed at the continued manufacture of products that deliver maximum performance with minimum maintenance.

SIZING INSTRUCTIONS

The performance or Sensible Heat Capacity of any evaporative cooler is a function of both the CFM and the efficiency, which should be considered as part of the sizing process. To help ensure proper sizing of an UltraCool, use the Index on the following page to locate Performance Data and Sizing Tables for a specific UltraCool model. Follow the procedure below to determine the cooler size.

1. Determine design conditions.
 - Outside Dry-Bulb
 - Outside Wet-Bulb
 - Inside Dry-Bulb (TI)
2. Determine the design Sensible Heat Load (Btuh).
3. Determine the cooler leaving air temperature (LAT) from the tables.
4. Determine CFM from the performance tables.
5. Calculate Sensible Heat Capacity of cooler using:
 $SHC = 1.08(TI - LAT)CFM$
6. Determine the number of coolers by dividing the Sensible Heat Load by the Sensible Heat Capacity.

EXAMPLE

- Outside Dry-Bulb = 105
- Outside Wet-Bulb = 65
- Inside Dry-Bulb = 80

Determine the number of AD100 UltraCool coolers with 2 horsepower motors required to cool 125,000 Btuh heat load. Assume .5" (water) external static pressure.

Using the Sizing Tables, the following information should be calculated:

$$\begin{aligned}LAT &= 72 \\CFM &= 7368 \\SHC &= 1.08(80-72)7368 = 63,660 \text{ Btuh} \\ \text{Number of Coolers} &= 125,000/63,660 = 2\end{aligned}$$

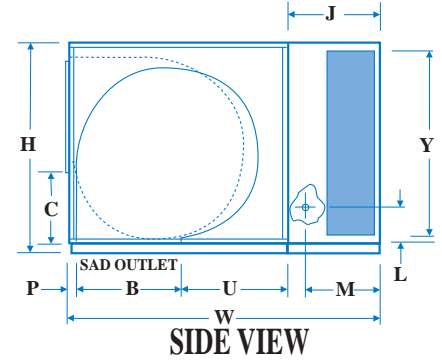
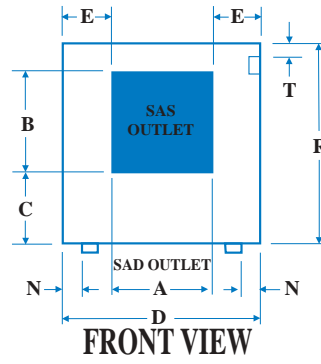
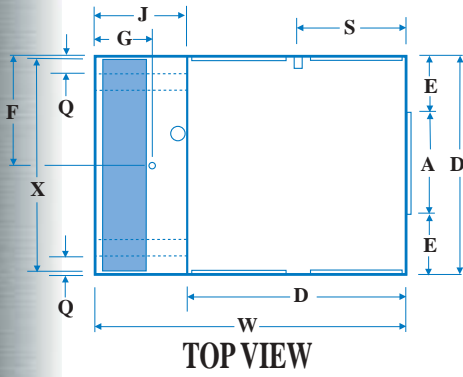

DIMENSIONAL DATA*

BLOWER MODEL NUMBER	WET MODULE NUMBER	CABINET			DUCT OPENING		DUCT LOCATION				DRAIN LOCATION		WET MODULE J	MEDIA DIMENSION		WATER SERVICE		ELECTRIC SERVICE		SKID LOCATIONS		
		H	W	D	A	B	C(SAS)	U(SAD)	P(SAD)	E	F	G		X	Y	L	M	S	T	N	Q	R
SAS/SAD 100B	100W	44	63 3/8	45	21 3/4	21 3/4	13 19/32	21 11/32	1 29/32	11 5/8	22 1/2	12 1/2	18 1/2	44 3/4	36 5/8	5 7/8	14 5/8	21 1/2	5 5/32	4 3/4	4 3/4	42
SAS/SAD 10012B	10012W	44	67 3/8	45	21 3/4	21 3/4	13 19/32	21 11/32	1 29/32	11 5/8	22 1/2	16 1/2	22 1/2	44 3/4	36 5/8	5 7/8	18 5/8	21 1/2	5 5/32	4 3/4	4 3/4	42
SAS/SAD 150B	150W	54	66 7/8	48 1/4	26 7/8	26 7/8	16 13/16	19 5/32	2 7/32	10 11/16	24 1/8	12 1/2	18 1/2	48	46 3/8	5 7/8	14 5/8	23 1/8	5 5/32	4 3/4	4 3/4	52
SAS/SAD 15012B	15012W	54	70 5/8	48 1/4	26 7/8	26 7/8	16 13/16	19 5/32	2 7/32	10 11/16	24 1/8	16 1/2	22 1/2	48	46 3/8	5 7/8	18 5/8	23 1/8	5 5/32	4 3/4	4 3/4	52

* All measurements in inches.

HOW TO USE THIS INDEX

Using the cooling requirement variables of Cooling Feet per Minute and External Static Pressure (shown as inches of water), locate the specific UltraCool model required and its corresponding page number. Turn to the indicated page for specific Performance Data and Sizing Tables. Follow the Sizing Instructions on the front inside cover to determine the UltraCool product for any cooling installation.

INDEX TABLE	PERFORMANCE <i>Certified Air Delivery At Various Increments Of Static Pressure (Inches Static Pressure Water Gauge)</i>										
	0"	0.1"	0.2"	0.3"	0.4"	0.5"	0.6"	0.7"	0.8"	0.9"	1.0"
MODEL & PAGE NO.	CFM	CFM	CFM	CFM	CFM	CFM	CFM	CFM	CFM	CFM	CFM
SAS/SAD 100 PAGE 2	5377	5121	4863	4605	4336	4058	3754	3429	3097	--	--
	5918	5684	5451	5215	4980	4734	4479	4209	3924	3619	3307
	6774	6574	6366	6164	5956	5751	5537	5320	5095	4859	4613
SAS/SAD 10012 PAGE 4	5371	5064	4794	4536	4269	3985	3667	3318	2952	2591	2261
	5911	5627	5375	5142	4907	4663	4399	4115	3809	3480	3145
	6767	6513	6286	6076	5872	5666	5456	5238	5008	4755	4497
SAS/SAD 150 PAGE 6	7072	6622	6203	5769	5298	4777	4201	3607	3041	2522	2040
	7783	7372	6987	6602	6199	5764	5285	4764	4231	3699	3199
	8910	8548	8205	7870	7533	7182	6812	6416	5993	5537	5067
	N/A	9476	9159	8855	8555	8244	7924	7592	7236	6866	6470
	N/A	N/A	N/A	N/A	N/A	N/A	N/A	9315	9032	8741	8436
SAS/SAD 15012 PAGE 8	6997	6539	6087	5603	5051	4415	3717	3058	2497	2013	1571
	7702	7286	6876	6450	5994	5477	4893	4260	3637	3085	2609
	8817	8455	8091	7734	7359	6961	6525	6050	5527	4976	4425
	N/A	9375	9044	8719	8389	8043	7683	7293	6869	6416	5932
	N/A	N/A	N/A	N/A	N/A	N/A	9377	9070	8751	8407	8046
AS/AD 100 PAGE 1	7745	7530	7275	7004	6729	6460	6193	5923	5646	5357	5045
	8524	8333	8109	7868	7618	7368	7123	6878	6638	6389	6137
	9758	9596	9407	9204	8990	8773	8556	8340	8124	7913	7698
	11569	11463	11285	11121	10950	10773	10592	10407	10224	10039	9856
AS/AD 10012 PAGE 3	7431	7255	7052	6835	6611	6376	6131	5877	5610	5327	5031
	8178	8024	7842	7649	7450	7244	7030	6809	6580	6343	6095
	9362	9235	9075	8914	8744	8572	8393	8209	8024	7827	7631
	11099	11001	10868	10736	10598	10457	10313	10165	10016	9862	9709
AS/AD 150 PAGE 5	11405	10892	10463	10064	9671	9276	8874	8456	8006	7530	7017
	13057	12600	12204	11844	11497	11153	10815	10467	10113	9741	9361
	15480	15082	14735	14410	14106	13810	13520	13234	12948	12659	12361
	17719	17364	17050	16756	16479	16214	15947	15694	15440	15188	14937
	11375	10905	10482	10079	9678	9265	8830	8366	7867	7325	6753
13020	12604	12225	11865	11514	11165	10807	10440	10058	9651	9220	
15438	15084	14749	14434	14133	13838	13540	13246	12949	12640	12328	
17672	17360	17060	16777	16505	16242	15983	15724	15463	15207	14947	
AS/AD/AU 20012 PAGE 9	16267	15716	15200	14696	14190	13665	13110	12521	11886	11194	10450
	19286	18820	18371	17943	17518	17092	16661	16211	15752	15272	14760
	22077	21670	21270	20888	20514	20142	19769	19395	19015	18629	18229
	24301	23929	23562	23204	22866	22528	22190	21852	21510	21171	20823

Performance shown is for installation type B - free inlet, ducted outlet. Power rating (BHP) does not include drive losses. Performance ratings do not include the effects of appurtenances in the airstream.

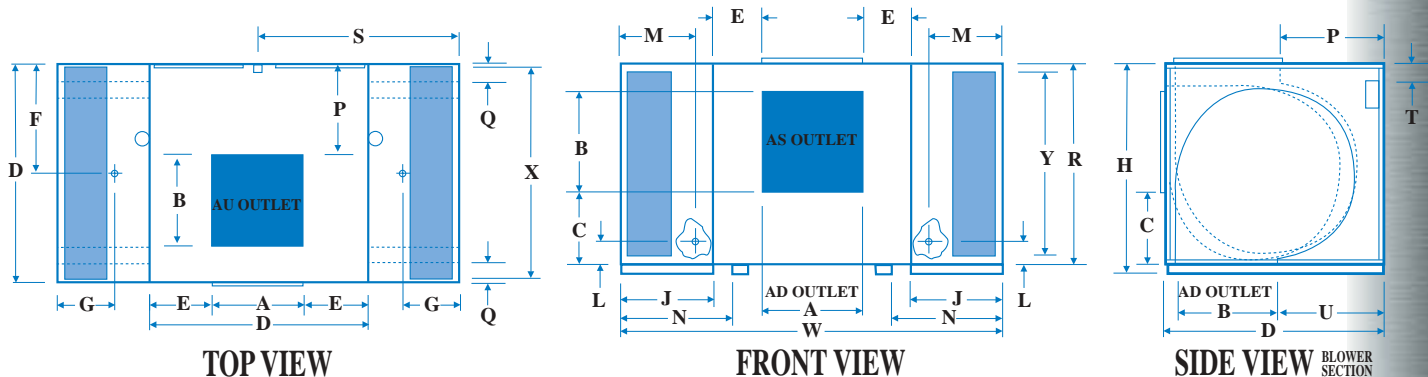

DIMENSIONAL DATA*

BLOWER MODEL NUMBER	WET MODULE NUMBER	CABINET			DUCT OPENING		DUCT LOCATION				DRAIN LOCATION		WET MODULE	MEDIA DIMENSION		WATER SERVICE		ELECTRIC SERVICE		SKID LOCATIONS		
		H	W	D	A	B	C(AS)	U(AD)	P(AU)	E	F	G		X	Y	L	M	S	T	N	Q	R
AS/AD 100B	100W	44	82	45	21 3/4	21 3/4	13 19/32	21 11/32	N/A	11 5/8	22 1/2	12 1/2	18 1/2	44 3/4	36 5/8	5 7/8	14 5/8	39 7/8	5 5/32	23 1/4	4 3/4	42
AS/AD 10012B	10012W	44	90	45	21 3/4	21 3/4	13 19/32	21 11/32	N/A	11 5/8	22 1/2	16 1/2	22 1/2	44 3/4	36 5/8	5 7/8	18 5/8	43 7/8	5 5/32	27 1/4	4 3/4	42
AS/AD 150B	150W	54	85 1/4	48 1/4	26 7/8	26 7/8	16 13/16	19 5/32	N/A	10 11/16	24 1/8	12 1/2	18 1/2	48	46 3/8	5 7/8	14 5/8	41 1/2	5 5/32	23 1/4	4 3/4	52
AS/AD 15012B	15012W	54	93 1/4	48 1/4	26 7/8	26 7/8	16 13/16	19 5/32	N/A	10 11/16	24 1/8	16 1/2	22 1/2	48	46 3/8	5 7/8	18 5/8	45 1/2	5 5/32	27 1/4	4 3/4	52
AS/AD/AU 20012B	20012W	59 1/4	105 1/4	60 1/4	31 3/4	31 3/4	18 11/16	25 1/4	24 29/32	14 1/4	30 1/8	16 1/8	22 1/2	60	51 3/8	5 7/8	18 5/8	51 5/8	5 5/32	27 1/4	4 3/4	57 1/4

*All measurements in inches.

SPECIFICATIONS PERFORMANCE *Certified Air Delivery At .1" Increments Of External Static Pressure (Inches Static Pressure Water Gauge)*

MAX B.H.P.	OPER. WGT.	AD MODEL BELT	AS MODEL BELT	0"		0.1"		0.2"		0.3"		0.4"		0.5"		0.6"		0.7"		0.8"		0.9"		1.0"	
				CFM	RPM	CFM	RPM	CFM	RPM	CFM	RPM	CFM	RPM	CFM	RPM	CFM	RPM	CFM	RPM	CFM	RPM	CFM	RPM	CFM	RPM
1 1/2	706	A76	A82	7745	364	7530	373	7275	384	7004	397	6729	409	6460	422	6193	434	5923	447	5646	460	5357	474	5045	489
2	710	B77	B83	8524	400	8333	408	8109	418	7868	429	7618	441	7368	452	7123	464	6878	475	6638	486	6389	498	6137	510
3	723	B80	B86	9758	458	9596	465	9407	473	9204	482	8990	492	8773	502	8556	512	8340	522	8124	532	7913	542	7698	552
5	739	B81	B87	11569	543	11463	549	11285	555	11121	563	10950	570	10773	578	10592	587	10407	595	10224	603	10039	612	9856	620

Performance shown is for installation type B - Free inlet. Ducted outlet. Power rating (BHP) does not include drive losses. Models AS/AD 100 include the affects of an 8 inch thick evaporative media on the inlet. When the Cooler Model No, Motor H.P., & Blower Speed are determined from the SPECIFICATION table above, use this information to select the proper pulley-belt kit from the SHEAVE SELECTION table below.

MOTOR SPECIFICATIONS

BLOWER MOTORS H.P.	SPEED	VOLTS	PHASE	MOTOR AMPS*	SHAFT DIA.	MOTOR WGT(LB)	MOTOR PART NO.	PUMP PART NO.	VOLTS	AMPS	WATTS	GPM (5 FT. HEAD)
1 1/2	1	208-230/460	3	6.6-6/3	7/8	40	110463-9	110468	230	0.58	77	4.6
2	1	115/208-230	1	24/13.2-12	7/8	49	110460	Pumps - 2 Required.				
2	1	208-230/460	3	7.5-6.8/3.4	7/8	44	110464-9					
3	1	208-230/460	3	10.6-9.6/4.8	1 1/8	83	110465-9					
5	1	208-230/460	3	16.7-15.2/7.6	1 1/8	87	110466-9					

*Amperage shown is from National Electrical Code. Use amperage shown on motor nameplate to determine motor protector.

SHEAVE SELECTION

MOTOR H.P.	MAUREY SHEAVE	SHEAVE BORE	AD MODEL BELT	AS MODEL BELT	BLOWER RPM/MOTOR SHEAVE 1/2 TURN DOWN											CHAMPION-AD PULLEY-BELT KIT NO.	CHAMPION-AS PULLEY-BELT KIT NO.	
					12	11	10	9	8	7	6	5	4	3	2			1
1-1/2	D8450	7/8	A76	A82	391	401	412	422	433	443	454	464	475	485	496	506	3DI-10	3DI-30
2	D8450	7/8	B77	B83	414	424	434	445	455	465	475	485	495	506	516	526	3DI-15	3DI-35
3	D8550	1 1/8	B80	B86	482	492	502	513	523	533	543	553	563	574	584	594	3DI-20	3DI-40
5	D8600	1 1/8	B81	B87	549	559	569	580	590	600	610	620	630	641	651	661	3DI-25	3DI-45

SIZING TABLES

OUTDOOR DRY BULB TEMP.	1-1/2 H.P. MOTOR / CFM-						2 H.P. MOTOR / CFM-SP*						3 H.P. MOTOR / CFM-SP*						5 H.P. MOTOR / CFM-SP*					
	7745 / 0 6460 / .5 5045 / 1.0						8524 / 0 7368 / .5 6137 / 1.0						9758 / 0 8773 / .5 7698 / 1.0						11569 / 0 10773 / .5 9856 / 1.0					
	OUTDOOR WET-BULB		75 65 55		75 65 55		OUTDOOR WET-BULB		75 65 55		75 65 55		OUTDOOR WET-BULB		75 65 55		75 65 55		OUTDOOR WET-BULB		75 65 55		75 65 55	
85	LAT	77 69 60	77 68 60	76 68 59	77 69 61	77 69 60	77 68 60	77 69 61	77 69 61	77 69 61	77 69 61	77 69 60	77 69 62	77 69 61	77 69 61	77 69 61	77 69 61	77 69 62	77 69 61	77 69 61	77 69 61	77 69 61	77 69 61	
95	LAT	79 70 62	78 70 61	78 69 60	79 71 62	79 70 62	78 70 61	79 71 63	79 71 63	79 71 63	79 71 63	79 70 62	79 72 64	79 71 63	79 71 63	79 71 63	79 71 63	79 72 64	79 71 63	79 71 63	79 71 63	79 71 63	79 71 63	
105	LAT	80 72 -	80 71 -	79 70 -	81 72 -	80 72 -	80 71 -	81 73 -	81 73 -	81 73 -	81 73 -	80 72 -	82 74 -	81 73 -	81 73 -	81 73 -	81 73 -	82 74 -	81 73 -	81 73 -	81 73 -	81 73 -	81 73 -	
115	LAT	82 74 -	81 73 -	80 72 -	82 74 -	82 74 -	81 73 -	83 75 -	83 75 -	83 75 -	83 75 -	82 74 -	84 76 -	83 75 -	83 75 -	83 75 -	83 75 -	84 76 -	83 75 -	83 75 -	83 75 -	83 75 -	83 75 -	
	GPH	31 38 -	26 33 -	21 26 -	33 42 -	29 37 -	25 31 -	38 47 -	34 43 -	31 38 -	31 38 -	44 54 -	41 51 -	38 47 -	38 47 -	38 47 -	44 54 -	41 51 -	38 47 -	38 47 -	38 47 -	38 47 -	38 47 -	

* Static Pressure (inches of water). GPH = Water consumption at design conditions but does not include bleed-off amount. Amount of bleed-off will vary with different water sources, but an amount equal to 10% of water consumption at any design condition is considered sufficient for average water. LAT = Cooler Discharge Temperature.

S / F / P / D 100

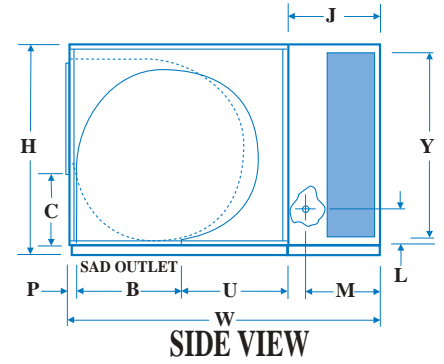
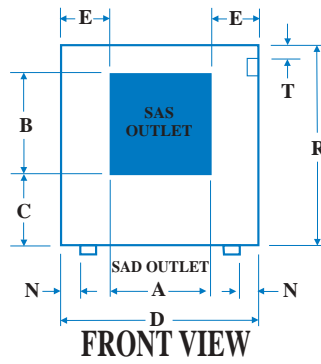
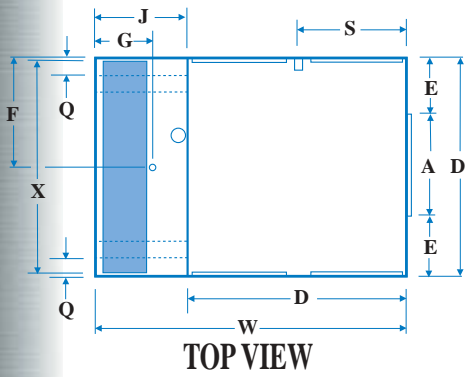

DIMENSIONAL DATA*

BLOWER MODEL NUMBER	WET MODULE NUMBER	CABINET			DUCT OPENING		DUCT LOCATION				DRAIN LOCATION		WET MODULE J	MEDIA DIMENSION		WATER SERVICE		ELECTRIC SERVICE		SKID LOCATIONS		
		H	W	D	A	B	C(SAS)	U(SAD)	P(SAD)	E	F	G		X	Y	L	M	S	T	N	Q	R
SAS/SAD 100B	100W	44	63 3/8	45	21 3/4	21 3/4	13 19/32	21 11/32	1 29/32	11 5/8	22 1/2	12 1/2	18 1/2	44 3/4	36 5/8	5 7/8	14 5/8	21 1/2	5 5/32	4 3/4	4 3/4	42
SAS/SAD 10012B	10012W	44	67 3/8	45	21 3/4	21 3/4	13 19/32	21 11/32	1 29/32	11 5/8	22 1/2	16 1/2	22 1/2	44 3/4	36 5/8	5 7/8	18 5/8	21 1/2	5 5/32	4 3/4	4 3/4	42
SAS/SAD 150B	150W	54	66 5/8	48 1/4	26 7/8	26 7/8	16 13/16	19 5/32	2 7/32	10 11/16	24 1/8	12 1/2	18 1/2	48	46 3/8	5 7/8	14 5/8	23 1/8	5 5/32	4 3/4	4 3/4	52
SAS/SAD 15012B	15012W	54	70 5/8	48 1/4	26 7/8	26 7/8	16 13/16	19 5/32	2 7/32	10 11/16	24 1/8	16 1/2	22 1/2	48	46 3/8	5 7/8	18 5/8	23 1/8	5 5/32	4 3/4	4 3/4	52

* All measurements in inches.

SPECIFICATIONS

PERFORMANCE *Certified Air Delivery At .1" Increments Of External Static Pressure (Inches Static Pressure Water Gauge)*

MAX B.H.P.	OPER. WGT.	SAD MODEL BELT	SAS MODEL BELT	0"		0.1"		0.2"		0.3"		0.4"		0.5"		0.6"		0.7"		0.8"		0.9"		1.0"	
				CFM	RPM	CFM	RPM	CFM	RPM	CFM	RPM	CFM	RPM	CFM	RPM	CFM	RPM	CFM	RPM	CFM	RPM	CFM	RPM	CFM	RPM
3/4	480	B77	B83	5377	352	5121	364	4863	376	4605	389	4336	402	4058	415	3754	430	3429	448	3097	469	--	--	--	--
1	483	B77	B83	5918	388	5684	398	5451	409	5215	421	4980	432	4734	444	4479	456	4209	470	3924	485	3619	503	3307	523
1 1/2	498	B77	B83	6774	444	6574	453	6366	463	6164	472	5956	482	5751	492	5537	502	5320	513	5095	524	4859	536	4613	548

Performance shown is for installation type B - Free inlet, Ducted outlet. Power rating (BHP) does not include drive losses. Models SAS/SAD 100 include the affects of an 8 inch thick evaporative media on the inlet. When the Cooler Model No, Motor H.P., & Blower Speed are determined from the SPECIFICATION table above, use this information to select the proper pulley-belt kit from the SHEAVE SELECTION table below.

MOTOR SPECIFICATIONS

BLOWER MOTORS		VOLTS	PHASE	MOTOR AMPS*	SHAFT DIA.	MOTOR WGT(LB)	MOTOR PART NO.	BLOWER MOTORS		VOLTS	PHASE	MOTOR AMPS*	SHAFT DIA.	MOTOR WGT(LB)	MOTOR PART NO.
H.P.	SPEED							H.P.	SPEED						
3/4	1	115/208-230	1	13.8/7.6-6.9	5/8	24	110455	1 1/2	1	115/208-230	1	20/11-10	7/8	41	110459
3/4	2	230	1	6.9	5/8	29	110456	1 1/2	1	208-230/460	3	6.6-6/3	7/8	40	110463-9
3/4	1	208-230/460	3	3.5-3.2/1.6	5/8	20	110461								
1	1	115/230	1	16/8	5/8	28	110457								
1	2	230	1	8	5/8	29	110458								
1	1	208-230/460	3	4.6-4.2/2.1	7/8	34	110462-9								

PUMP PART NO.	VOLTS	AMPS	WATTS	GPM (5 FT. HEAD)
110467	115	1.0	73	4.6
110468	230	0.58	77	4.6

*Amperage shown is from National Electrical Code. Use amperage shown on motor nameplate to determine motor protector. Pumps - 1 Required.

SHEAVE SELECTION

MOTOR H.P.	MAUREY SHEAVE	SHEAVE BORE	SAD MODEL BELT	SAS MODEL BELT	BLOWER RPM/MOTOR SHEAVE 1/2 TURN DOWN											CHAMPION-SAD PULLEY-BELT KIT NO.	CHAMPION-SAS PULLEY-BELT KIT NO.	
					12	11	10	9	8	7	6	5	4	3	2			1
3/4, 1	8350K	5/8*	B77	B83	303	313	323	333	343	353	364	374	384	394	404	414	3DI-90	3DI-110
	8450K	5/8*	B77	B83	414	424	434	445	455	465	475	485	495	506	516	526		
1	8350	7/8*	B77	B83	303	313	323	333	343	353	364	374	384	394	404	414	3DI-100	3DI-120
1, 1 1/2	8450K	7/8*	B77	B83	414	424	434	445	455	465	475	485	495	506	516	526	3DI-105	3DI-125

*When selecting 1 H.P. motor, be sure to select Pulley-Belt Kit with same pulley bore as shaft size of motor selected.

SIZING TABLES

OUTDOOR DRY BULB TEMP.	3/4 H.P. MOTOR / CFM-SP*			1 H.P. MOTOR / CFM-SP*			1-1/2 H.P. MOTOR / CFM-SP*						
	5435 / 0 4118 / .5 2197 / 1.0			5983 / 0 4856 / .5 3092 / 1.0			6848 / 0 5942 / .5 4639 / 1.0						
	OUTDOOR WET-BULB			OUTDOOR WET-BULB			OUTDOOR WET-BULB						
85	LAT	77 69 61	77 69 60	76 67 59	77 69 62	77 69 61	77 68 60	77 70 62	77 69 61	77 69 61	77 69 61	77 69 61	77 69 61
	GPH	5 10 15	4 8 12	2 5 7	6 11 17	5 9 14	3 6 9	6 13 19	6 11 17	4 9 13	4 9 13	4 9 13	4 9 13
95	LAT	79 71 63	79 70 62	77 69 60	79 72 64	79 71 63	78 70 61	80 72 64	79 71 64	79 71 63	79 71 63	79 71 63	79 71 63
	GPH	10 15 21	8 12 16	5 7 9	11 17 22	9 14 19	6 9 13	13 19 25	11 17 22	9 13 18	9 13 18	9 13 18	9 13 18
105	LAT	81 73 -	80 72 -	79 70 -	82 74 -	81 73 -	80 71 -	82 74 -	81 74 -	81 73 -	81 73 -	81 73 -	81 73 -
	GPH	15 21 -	12 16 -	7 9 -	17 22 -	14 19 -	9 13 -	19 25 -	17 22 -	13 18 -	13 18 -	13 18 -	13 18 -
115	LAT	83 75 -	82 74 -	80 71 -	84 76 -	83 75 -	81 73 -	84 77 -	84 76 -	83 75 -	83 75 -	83 75 -	83 75 -
	GPH	21 26 -	16 21 -	9 12 -	22 28 -	19 23 -	13 16 -	25 32 -	22 28 -	18 22 -	18 22 -	18 22 -	18 22 -

* Static Pressure (inches of water). GPH = Water consumption at design conditions but does not include bleed-off amount. Amount of bleed-off will vary with different water sources, but an amount equal to 10% of water consumption at any design condition is considered sufficient for average water. LAT = Cooler Discharge Temperature.

SAS/SAD 100

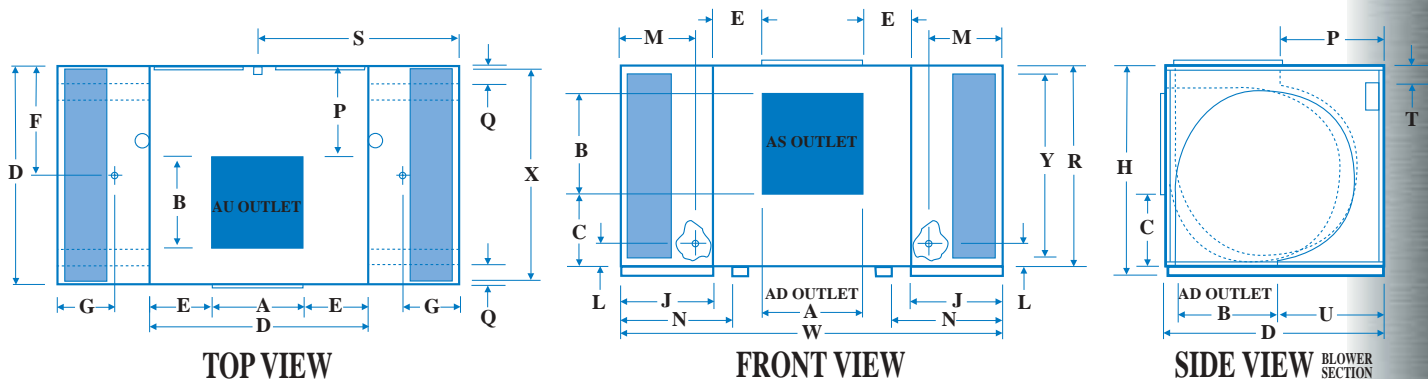

DIMENSIONAL DATA*

BLOWER MODEL NUMBER	WET MODULE NUMBER	CABINET			DUCT OPENING		DUCT LOCATION				DRAIN LOCATION		WET MODULE	MEDIA DIMENSION		WATER SERVICE		ELECTRIC SERVICE		SKID LOCATIONS		
		H	W	D	A	B	C(AS)	U(AD)	P(AU)	E	F	G		X	Y	L	M	S	T	N	Q	R
AS/AD 100B	100W	44	82	45	21 3/4	21 3/4	13 19/32	21 11/32	N/A	11 5/8	22 1/2	12 1/2	18 1/2	44 3/4	36 5/8	5 7/8	14 5/8	39 7/8	5 5/32	23 1/4	4 3/4	42
AS/AD 10012B	10012W	44	90	45	21 3/4	21 3/4	13 19/32	21 11/32	N/A	11 5/8	22 1/2	16 1/2	22 1/2	44 3/4	36 5/8	5 7/8	18 5/8	43 7/8	5 5/32	27 1/4	4 3/4	42
AS/AD 150B	150W	54	85 1/4	48 1/4	26 7/8	26 7/8	16 13/16	19 5/32	N/A	10 11/16	24 1/8	12 1/2	18 1/2	48	46 3/8	5 7/8	14 5/8	41 1/2	5 5/32	23 1/4	4 3/4	52
AS/AD 15012B	15012W	54	93 1/4	48 1/4	26 7/8	26 7/8	16 13/16	19 5/32	N/A	10 11/16	24 1/8	16 1/2	22 1/2	48	46 3/8	5 7/8	18 5/8	45 1/2	5 5/32	27 1/4	4 3/4	52
AS/AD/AU 20012B	20012W	59 1/4	105 1/4	60 1/4	31 3/4	31 3/4	18 11/16	25 1/4	24 29/32	14 1/4	30 1/8	16 1/8	22 1/2	60	51 3/8	5 7/8	18 5/8	51 5/8	5 5/32	27 1/4	4 3/4	57 1/4

* All measurements in inches.

SPECIFICATIONS PERFORMANCE Certified Air Delivery At 1" Increments Of External Static Pressure (Inches Static Pressure Water Gauge)

MAX B.H.P.	OPER. WGT.	AD MODEL BELT	AS MODEL BELT	0"		0.1"		0.2"		0.3"		0.4"		0.5"		0.6"		0.7"		0.8"		0.9"		1.0"	
				CFM	RPM	CFM	RPM	CFM	RPM	CFM	RPM	CFM	RPM	CFM	RPM	CFM	RPM	CFM	RPM	CFM	RPM	CFM	RPM	CFM	RPM
1 1/2	801	A76	A82	7431	382	7255	390	7052	400	6835	411	6611	424	6376	437	6131	450	5877	464	5610	477	5327	492	5031	507
2	805	B77	B83	8178	421	8024	427	7842	436	7649	446	7450	457	7244	468	7030	480	6809	492	6580	504	6343	517	6095	529
3	818	B80	B86	9362	482	9235	487	9075	494	8914	502	8744	511	8572	520	8393	531	8209	541	8024	551	7827	562	7631	672
5	834	B81	B87	11099	571	11001	575	10868	581	10736	587	10598	594	10457	601	10313	609	10165	617	10016	625	9862	634	9709	643

Performance shown is for installation type B - Free inlet, Ducted outlet. Power rating (BHP) does not include drive losses. Models AS/AD 10012 include the affects of a 12 inch thick evaporative media on the inlet. When the Cooler Model No, Motor H.P., & Blower Speed are determined from the SPECIFICATION table above, use this information to select the proper pulley-belt kit from the SHEAVE SELECTION table below.

MOTOR SPECIFICATIONS

BLOWER MOTORS H.P.	SPEED	VOLTS	PHASE	MOTOR AMPS*	SHAFT DIA.	MOTOR WGT(LB)	MOTOR PART NO.	PUMP PART NO.	VOLTS	AMPS	WATTS	GPM (5 FT. HEAD)
1 1/2	1	208-230/460	3	6.6-6/3	7/8	40	110463-9	110468	230	0.58	77	4.6
2	1	115/208-230	1	24/13.2-12	7/8	49	110460	Pumps - 2 Required.				
2	1	208-230/460	3	7.5-6.8/3.4	7/8	44	110464-9					
3	1	208-230/460	3	10.6-9.6/4.8	1 1/8	83	110465-9					
5	1	208-230/460	3	16.7-15.2/7.6	1 1/8	87	110466-9					

*Amperage shown is from National Electrical Code. Use amperage shown on motor nameplate to determine motor protector.

SHEAVE SELECTION

MOTOR H.P.	MAUREY SHEAVE	SHEAVE BORE	AD MODEL BELT	AS MODEL BELT	BLOWER RPM/MOTOR SHEAVE 1/2 TURN DOWN											CHAMPION-AD PULLEY-BELT KIT NO.	CHAMPION-AS PULLEY-BELT KIT NO.	
					12	11	10	9	8	7	6	5	4	3	2			1
1-1/2	D8450	7/8	A76	A82	391	401	412	422	433	443	454	464	475	485	496	506	3DI-10	3DI-30
2	D8450	7/8	B77	B83	414	424	434	445	455	465	475	485	495	506	516	526	3DI-15	3DI-35
3	D8550	1 1/8	B80	B86	482	492	502	513	523	533	543	553	563	574	584	594	3DI-20	3DI-40
5	D8600	1 1/8	B81	B87	549	559	569	580	590	600	610	620	630	641	651	661	3DI-25	3DI-45

SIZING TABLES

OUTDOOR DRY BULB TEMP.	1-1/2 H.P. MOTOR / CFM-SP*				2 H.P. MOTOR / CFM-SP*				3 H.P. MOTOR / CFM-SP*				5 H.P. MOTOR / CFM-SP*												
	7431 / 0 6376 / .5 5031 / 1.0				8178 / 0 7244 / .5 6095 / 1.0				9362 / 0 8572 / .5 7631 / 1.0				11099 / 0 10457 / .5 9709 / 1.0												
	OUTDOOR WET-BULB				OUTDOOR WET-BULB				OUTDOOR WET-BULB				OUTDOOR WET-BULB												
85	LAT	76 67 58	76 67 58	76 67 57	76 67 58	76 67 58	76 67 58	76 67 58	76 67 58	76 67 58	76 67 58	76 67 58	76 67 58	76 67 58	76 67 58	76 67 58	76 67 58	76 67 58	76 67 58	76 67 58	76 67 58	76 67 58	76 67 58	76 67 58	
95	LAT	77 68 59	77 68 59	77 67 58	77 68 59	77 68 59	77 68 59	77 68 59	77 68 59	77 68 59	77 68 59	77 68 59	77 68 59	77 68 60	77 68 59	77 68 59	77 68 59	77 68 59	77 68 59	77 68 59	77 68 59	77 68 59	77 68 59	77 68 59	77 68 59
105	LAT	78 69 -	78 69 -	77 68 -	78 69 -	78 69 -	78 69 -	78 69 -	78 69 -	78 69 -	78 69 -	78 69 -	78 69 -	78 70 -	78 69 -	78 69 -	78 69 -	78 69 -	78 69 -	78 69 -	78 69 -	78 69 -	78 69 -	78 69 -	78 69 -
115	LAT	79 70 -	79 70 -	78 69 -	79 70 -	79 70 -	79 69 -	79 70 -	79 70 -	79 70 -	79 70 -	79 70 -	79 70 -	80 71 -	79 71 -	79 71 -	79 71 -	79 71 -	79 71 -	79 71 -	79 71 -	79 71 -	79 71 -	79 71 -	79 71 -
	GPH	17 25 34	14 21 28	11 17 22	18 28 37	16 24 32	13 20 27	21 32 42	19 28 38	17 25 32	25 37 49	23 34 46	21 32 42	34 46	32 42	30 38	28 36	26 34	24 32	22 30	20 28	18 26	16 24	14 22	12 20

* Static Pressure (inches of water). GPH = Water consumption at design conditions but does not include bleed-off amount. Amount of bleed-off will vary with different water sources, but an amount equal to 10% of water consumption at any design condition is considered sufficient for average water. LAT = Cooler Discharge Temperature.

AS/AD 10012

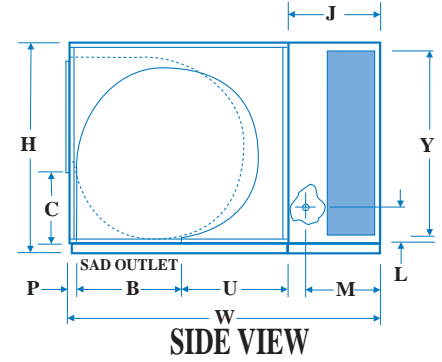
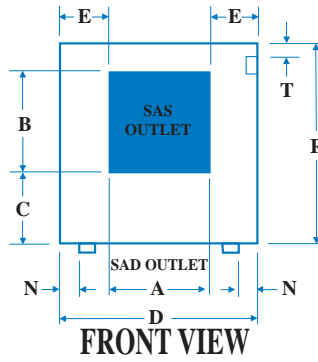
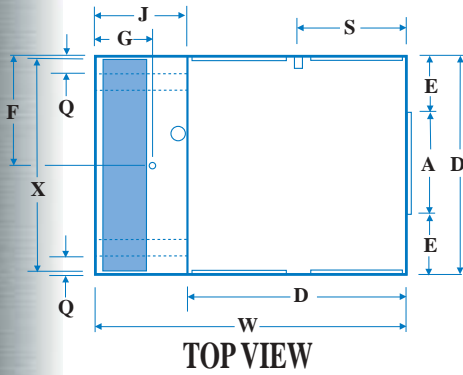

DIMENSIONAL DATA*

BLOWER MODEL NUMBER	WET MODULE NUMBER	CABINET			DUCT OPENING		DUCT LOCATION				DRAIN LOCATION		WET MODULE J	MEDIA DIMENSION		WATER SERVICE		ELECTRIC SERVICE		SKID LOCATIONS		
		H	W	D	A	B	C(SAS)	U(SAD)	P(SAD)	E	F	G		X	Y	L	M	S	T	N	Q	R
SAS/SAD 100B	100W	44	63 3/8	45	21 3/4	21 3/4	13 19/32	21 11/32	1 29/32	11 5/8	22 1/2	12 1/2	18 1/2	44 3/4	36 5/8	5 7/8	14 5/8	21 1/2	5 5/32	4 3/4	4 3/4	42
SAS/SAD 10012B	10012W	44	67 3/8	45	21 3/4	21 3/4	13 19/32	21 11/32	1 29/32	11 5/8	22 1/2	16 1/2	22 1/2	44 3/4	36 5/8	5 7/8	18 5/8	21 1/2	5 5/32	4 3/4	4 3/4	42
SAS/SAD 150B	150W	54	66 5/8	48 1/4	26 7/8	26 7/8	16 13/16	19 5/32	2 7/32	10 11/16	24 1/8	12 1/2	18 1/2	48	46 3/8	5 7/8	14 5/8	23 1/8	5 5/32	4 3/4	4 3/4	52
SAS/SAD 15012B	15012W	54	70 5/8	48 1/4	26 7/8	26 7/8	16 13/16	19 5/32	2 7/32	10 11/16	24 1/8	16 1/2	22 1/2	48	46 3/8	5 7/8	18 5/8	23 1/8	5 5/32	4 3/4	4 3/4	52

* All measurements in inches.

SPECIFICATIONS

PERFORMANCE *Certified Air Delivery At .1" Increments Of External Static Pressure (Inches Static Pressure Water Gauge)*

MAX B.H.P.	OPER. WGT.	SAD MODEL BELT	SAS MODEL BELT	0"		0.1"		0.2"		0.3"		0.4"		0.5"		0.6"		0.7"		0.8"		0.9"		1.0"	
				CFM	RPM	CFM	RPM	CFM	RPM	CFM	RPM	CFM	RPM	CFM	RPM	CFM	RPM	CFM	RPM	CFM	RPM	CFM	RPM	CFM	RPM
3/4	527	B77	B83	5371	362	5064	374	4794	386	4536	397	4269	410	3985	423	3667	439	3318	458	2952	481	2591	507	2261	534
1	530	B77	B83	5911	359	5627	410	5375	420	5142	431	4907	441	4663	453	4399	465	4115	479	3809	495	3480	514	3145	536
1 1/2	545	B77	B83	6767	457	6513	466	6286	475	6076	484	5872	494	5666	503	5456	513	5238	523	5008	534	4755	546	4497	560

Performance shown is for installation type B - Free inlet, Ducted outlet. Power rating (BHP) does not include drive losses. Models SAS/SAD 10012 include the affects of a 12 inch thick evaporative media on the inlet. When the Cooler Model No, Motor H.P. & Blower Speed are determined from the SPECIFICATION table above, use this information to select the proper pulley-belt kit from the SHEAVE SELECTION table below.

MOTOR SPECIFICATIONS

BLOWER MOTORS		VOLTS	PHASE	MOTOR AMPS*	SHAFT DIA.	MOTOR WGT(LB)	MOTOR PART NO.	BLOWER MOTORS		VOLTS	PHASE	MOTOR AMPS*	SHAFT DIA.	MOTOR WGT(LB)	MOTOR PART NO.
H.P.	SPEED							H.P.	SPEED						
3/4	1	115/208-230	1	13.8/7.6-6.9	5/8	24	110455	1 1/2	1	115/208-230	1	20/11-10	7/8	41	110459
3/4	2	230	1	6.9	5/8	29	110456	1 1/2	1	208-230/460	3	6.6/6/3	7/8	40	110463-9
3/4	1	208-230/460	3	3.5-3.2/1.6	5/8	20	110461								
1	1	115/230	1	16/8	5/8	28	110457								
1	2	230	1	8	5/8	29	110458								
1	1	208-230/460	3	4.6-4.2/2.1	7/8	34	110462-9								

PUMP PART NO.	VOLTS	AMPS	WATTS	GPM (5 FT. HEAD)
110467	115	1.0	73	4.6
110468	230	0.58	77	4.6

*Amperage shown is from National Electrical Code. Use amperage shown on motor nameplate to determine motor protector.

Pumps - 1 Required.

SHEAVE SELECTION

MOTOR H.P.	MAUREY SHEAVE	SHEAVE BORE	SAD MODEL BELT	SAS MODEL BELT	BLOWER RPM/MOTOR SHEAVE 1/2 TURN DOWN												CHAMPION-SAD PULLEY-BELT KIT NO.	CHAMPION-SAS PULLEY-BELT KIT NO.
					12	11	10	9	8	7	6	5	4	3	2	1		
3/4, 1	8350K	5/8*	B77	B83	303	313	323	333	343	353	364	374	384	394	404	414	3DI-90	3DI-110
3/4, 1	8450K	5/8*	B77	B83	414	424	434	445	455	465	475	485	495	506	516	526	3DI-95	3DI-115
1	8350	7/8*	B77	B83	303	313	323	333	343	353	364	374	384	394	404	414	3DI-100	3DI-120
1, 1 1/2	8450K	7/8*	B77	B83	414	424	434	445	455	465	475	485	495	506	516	526	3DI-105	3DI-125

*When selecting 1 H.P. motor, be sure to select Pulley-Belt Kit with same pulley bore as shaft size of motor selected.

SIZING TABLES

OUTDOOR DRY BULB TEMP.		3/4 H.P. MOTOR / CFM-SP*			1 H.P. MOTOR / CFM-SP*			1-1/2 H.P. MOTOR / CFM-SP*		
		5377 / 0	4007 / .5	2120 / 1.0	5917 / 0	4712 / .5	2970 / 1.0	6761 / 0	5761 / .5	4447 / 1.0
		OUTDOOR WET-BULB			OUTDOOR WET-BULB			OUTDOOR WET-BULB		
85	LAT	76 67 58	76 67 58	76 66 57	76 67 58	76 67 58	76 67 58	76 67 58	76 67 58	76 67 58
	GPH	6 12 17	6 12 13	2 5 7	6 13 19	6 13 19	5 10 16	7 14 22	6 12 18	5 10 15
95	LAT	77 68 59	77 68 59	76 67 58	77 68 59	77 68 59	77 68 58	77 69 60	77 68 60	77 68 59
	GPH	12 17 23	12 17 23	5 7 9	13 19 25	10 15 20	7 10 13	14 22 29	12 18 25	10 15 19
105	LAT	78 69 -	78 69 -	77 68 -	78 69 -	78 69 -	78 68 -	79 70 -	78 70 -	78 69 -
	GPH	17 23 -	12 16 -	7 9 -	19 25 -	15 20 -	10 13 -	22 29 -	18 25 -	15 19 -
115	LAT	79 70 -	79 70 -	78 68 -	79 71 -	79 70 -	78 69 -	80 71 -	80 71 -	79 70 -
	GPH	23 29 -	16 20 -	9 11 -	25 32 -	20 25 -	13 16 -	29 36 -	25 31 -	19 24 -

* Static Pressure (inches of water). GPH = Water consumption at design conditions but does not include bleed-off amount. Amount of bleed-off will vary with different water sources, but an amount equal to 10% of water consumption at any design condition is considered sufficient for average water. LAT = Cooler Discharge Temperature.

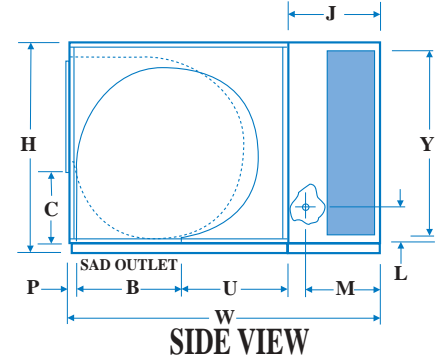
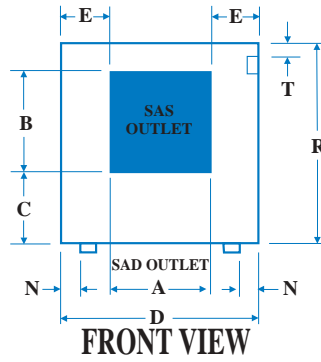
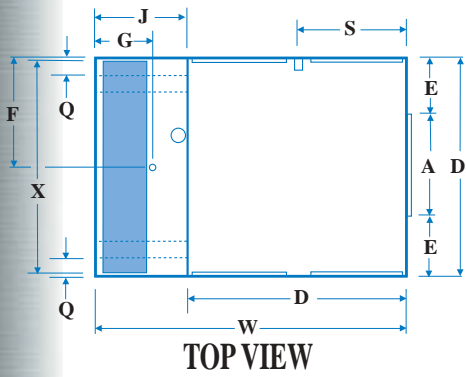

DIMENSIONAL DATA*

BLOWER MODEL NUMBER	WET MODULE NUMBER	CABINET			DUCT OPENING		DUCT LOCATION				DRAIN LOCATION		WET MODULE J	MEDIA DIMENSION		WATER SERVICE		ELECTRIC SERVICE		SKID LOCATIONS		
		H	W	D	A	B	C(SAS)	U(SAD)	P(SAD)	E	F	G		X	Y	L	M	S	T	N	Q	R
SAS/SAD 100B	100W	44	63 3/8	45	21 3/4	21 3/4	13 19/32	21 11/32	1 29/32	11 5/8	22 1/2	12 1/2	18 1/2	44 3/4	36 5/8	5 7/8	14 5/8	21 1/2	5 5/32	4 3/4	4 3/4	42
SAS/SAD 10012B	10012W	44	67 3/8	45	21 3/4	21 3/4	13 19/32	21 11/32	1 29/32	11 5/8	22 1/2	16 1/2	22 1/2	44 3/4	36 5/8	5 7/8	18 5/8	21 1/2	5 5/32	4 3/4	4 3/4	42
SAS/SAD 150B	150W	54	66 5/8	48 1/4	26 7/8	26 7/8	16 13/16	19 5/32	2 7/32	10 11/16	24 1/8	12 1/2	18 1/2	48	46 3/8	5 7/8	14 5/8	23 1/8	5 5/32	4 3/4	4 3/4	52
SAS/SAD 15012B	15012W	54	70 5/8	48 1/4	26 7/8	26 7/8	16 13/16	19 5/32	2 7/32	10 11/16	24 1/8	16 1/2	22 1/2	48	46 3/8	5 7/8	18 5/8	23 1/8	5 5/32	4 3/4	4 3/4	52

* All measurements in inches.

SPECIFICATIONS

PERFORMANCE *Certified Air Delivery At .1" Increments Of External Static Pressure (Inches Static Pressure Water Gauge)*

MAX B.H.P.	OPER. WGT.	SAD MODEL BELT	SAS MODEL BELT	0"		0.1"		0.2"		0.3"		0.4"		0.5"		0.6"		0.7"		0.8"		0.9"		1.0"	
				CFM	RPM	CFM	RPM	CFM	RPM	CFM	RPM	CFM	RPM	CFM	RPM	CFM	RPM	CFM	RPM	CFM	RPM	CFM	RPM	CFM	RPM
3/4	584	B90	B96	7072	275	6622	287	6203	298	5769	308	5298	321	4777	336	4201	355	3607	378	3041	402	2522	424	2040	443
1	593	B90	B96	7783	302	7372	314	6987	324	6602	333	6199	343	5764	355	5285	369	4764	386	4231	406	3699	427	3199	448
1 1/2	608	B90	B96	8910	346	8548	356	8205	365	7870	374	7533	382	7182	391	6812	401	6416	412	5993	424	5537	439	5067	456
2	612	B90	B96	N/A	N/A	9476	390	9159	399	8855	406	8555	414	8244	421	7924	430	7592	438	7236	448	6866	459	6470	471
3	624	B92	B100	N/A	N/A	N/A	N/A	N/A	N/A	N/A	N/A	N/A	N/A	N/A	N/A	N/A	N/A	9315	486	9032	493	8741	500	8436	509

Performance shown is for installation type B - Free inlet, Ducted outlet. Power rating (BHP) does not include drive losses. Models SAS/SAD 150 include the affects of an 8 inch thick evaporative media on the inlet. When the Cooler Model No, Motor H.P., & Blower Speed are determined from the SPECIFICATION table above, use this information to select the proper pulley-belt kit from the SHEAVE SELECTION table below.

MOTOR SPECIFICATIONS

BLOWER MOTORS		VOLTS	PHASE	MOTOR AMPS*	SHAFT DIA.	MOTOR WGT(LB)	MOTOR PART NO.
H.P.	SPEED						
3/4	1	115/208-230	1	13.8/7.6-6.9	5/8	24	110455
3/4	2	230	1	6.9	5/8	29	110456
3/4	1	208-230/460	3	3.5-3.2/1.6	5/8	20	110461
1	1	115/230	1	16/8	5/8	28	110457
1	2	230	1	8	5/8	29	110458
1	1	208-230/460	3	4.6-4.2/2.1	7/8	34	110462-9
1 1/2	1	115/208-230	1	20/11-10	7/8	41	110459
1 1/2	1	208-230/460	3	6.6-6/3	7/8	40	110463-9

BLOWER MOTORS		VOLTS	PHASE	MOTOR AMPS*	SHAFT DIA.	MOTOR WGT(LB)	MOTOR PART NO.
H.P.	SPEED						
2	1	115/208-230	1	24/13.2-12	7/8	49	110460
2	1	208-230/460	3	7.5-6.8/3.4	7/8	44	110464-9
3	1	208-230/460	3	10.6-9.6/4.8	1 1/8	83	110465-9

PUMP PART NO.	VOLTS	AMPS	WATTS	GPM (5 FT. HEAD)
110467	115	1.0	73	4.6
110468	230	0.58	77	4.6

*Amperage shown is from National Electrical Code. Use amperage shown on motor nameplate to determine motor protector.

Pumps - 1 Required.

SHEAVE SELECTION

MOTOR H.P.	MAUREY SHEAVE	SHEAVE BORE	SAD MODEL BELT	SAS MODEL BELT	BLOWER RPM/MOTOR SHEAVE 1/2 TURN DOWN										CHAMPION-SAD PULLEY-BELT KIT NO.	CHAMPION-SAS PULLEY-BELT KIT NO.		
					12	11	10	9	8	7	6	5	4	3			2	1
3/4, 1	8350K	5/8*	B90	B96	253	261	269	278	287	296	304	313	321	330	338	347	3DI-130	3DI-165
3/4, 1	8450K	5/8*	B90	B96	347	356	364	373	381	390	398	407	415	424	432	441	3DI-135	3DI-170
1	8350	7/8*	B90	B96	253	261	269	278	287	296	304	313	321	330	338	347	3DI-140	3DI-175
1, 1 1/2, 2	8450K	7/8*	B90	B96	347	356	364	373	381	390	398	407	415	424	432	441	3DI-145	3DI-180
1 1/2, 2	8550	7/8	B90	B96	403	412	420	429	437	446	454	463	471	480	488	497	3DI-155	3DI-185
3	8550	1 1/8	B92	B100	403	412	420	429	437	446	454	463	471	480	488	497	3DI-161	3DI-190

*When selecting 1 H.P. motor, be sure to select Pulley-Belt Kit with same pulley bore as shaft size of motor selected.

SIZING TABLES

OUTDOOR DRY BULB TEMP.	LAT	3/4 H.P. MOTOR / CFM-SP*			1 H.P. MOTOR / CFM-SP*			1-1/2 H.P. MOTOR / CFM-SP*			2 H.P. MOTOR / CFM-SP*			3 H.P. MOTOR / CFM-SP*		
		7072 / 0 4777 / .5 2040 / 1.0			7783 / 0 5764 / .5 3199 / 1.0			8910 / 0 7182 / .5 5067 / 1.0			9476 / .1 8244 / .5 6470 / 1.0			9315 / .7 8436 / 1.0		
		OUTDOOR WET-BULB			OUTDOOR WET-BULB			OUTDOOR WET-BULB			OUTDOOR WET-BULB			OUTDOOR WET-BULB		
85	LAT	77 69 61	77 68 60	76 68 59	77 69 62	77 69 61	76 68 59	78 70 62	77 69 61	77 68 60	77 70 62	77 70 62	77 69 61	- - -	77 70 62	77 70 62
	GPH	7 14 21	5 9 14	2 5 7	8 15 23	6 11 17	3 7 10	8 17 25	7 14 20	5 9 14	9 17 26	8 15 23	6 12 18	- - -	9 17 26	8 15 23
95	LAT	79 71 63	78 70 62	78 69 61	79 72 64	79 71 62	78 69 61	80 72 64	79 71 63	79 70 62	80 72 64	80 72 64	79 71 63	- - -	80 72 64	80 72 64
	GPH	14 21 28	9 14 18	5 7 9	15 23 30	11 17 22	7 10 14	17 25 34	14 20 27	9 14 19	17 26 34	15 23 31	12 18 24	- - -	17 26 34	15 23 31
105	LAT	81 73 -	80 72 -	79 71 -	82 74 -	81 72 -	79 71 -	82 74 -	81 73 -	80 72 -	82 74 -	81 73 -	- - -	82 74 -	82 74 -	82 74 -
	GPH	21 28 -	14 18 -	7 9 -	23 30 -	17 22 -	10 14 -	25 34 -	20 27 -	14 19 -	26 34 -	23 31 -	18 24 -	- - -	26 34 -	23 31 -
115	LAT	83 75 -	82 73 -	81 72 -	84 76 -	82 74 -	81 72 -	84 77 -	83 75 -	82 73 -	84 77 -	84 76 -	83 75 -	- - -	84 77 -	84 76 -
	GPH	28 35 -	18 23 -	9 11 -	30 38 -	22 28 -	14 17 -	34 42 -	27 34 -	19 23 -	34 43 -	31 39 -	24 30 -	- - -	34 43 -	31 39 -

* Static Pressure (inches of water). GPH = Water consumption at design conditions but does not include bleed-off amount. Amount of bleed-off will vary with different water sources, but an amount equal to 10% of water consumption at any design condition is considered sufficient for average water. LAT = Cooler Discharge Temperature.

SAS/SAD 150

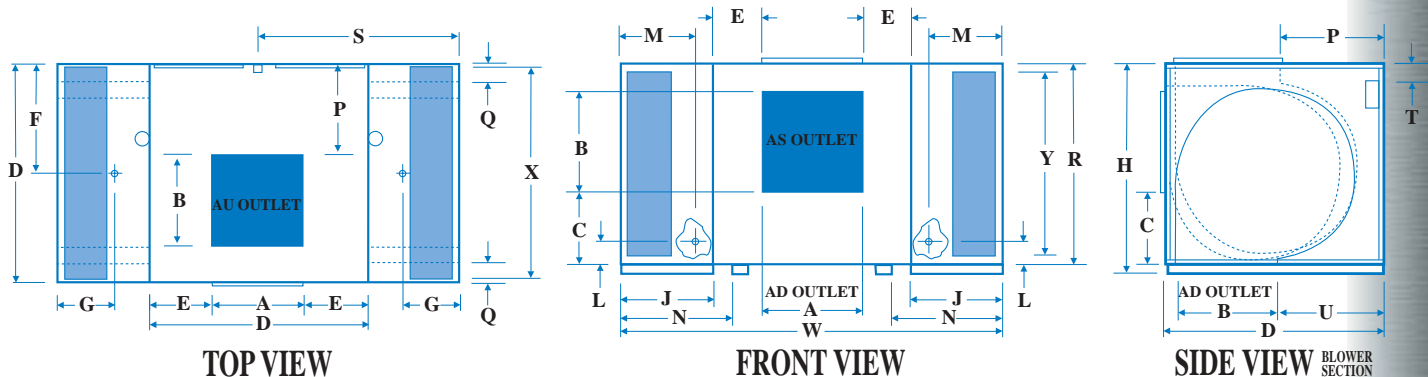

DIMENSIONAL DATA*

BLOWER MODEL NUMBER	WET MODULE NUMBER	CABINET			DUCT OPENING		DUCT LOCATION				DRAIN LOCATION		WET MODULE	MEDIA DIMENSION		WATER SERVICE		ELECTRIC SERVICE		SKID LOCATIONS		
		H	W	D	A	B	C(AS)	U(AD)	P(AU)	E	F	G		X	Y	L	M	S	T	N	Q	R
AS/AD 100B	100W	44	82	45	21 3/4	21 3/4	13 19/32	21 11/32	N/A	11 5/8	22 1/2	12 1/2	18 1/2	44 3/4	36 5/8	5 7/8	14 5/8	39 7/8	5 5/32	23 1/4	4 3/4	42
AS/AD 10012B	10012W	44	90	45	21 3/4	21 3/4	13 19/32	21 11/32	N/A	11 5/8	22 1/2	16 1/2	22 1/2	44 3/4	36 5/8	5 7/8	18 5/8	43 7/8	5 5/32	27 1/4	4 3/4	42
AS/AD 150B	150W	54	85 1/4	48 1/4	26 7/8	26 7/8	16 13/16	19 5/32	N/A	10 11/16	24 1/8	12 1/2	18 1/2	48	46 3/8	5 7/8	14 5/8	41 1/2	5 5/32	23 1/4	4 3/4	52
AS/AD 15012B	15012W	54	93 1/4	48 1/4	26 7/8	26 7/8	16 13/16	19 5/32	N/A	10 11/16	24 1/8	16 1/2	22 1/2	48	46 3/8	5 7/8	18 5/8	45 1/2	5 5/32	27 1/4	4 3/4	52
AS/AD/AU 20012B	20012W	59 1/4	105 1/4	60 1/4	31 3/4	31 3/4	18 11/16	25 1/4	24 29/32	14 1/4	30 1/8	16 1/8	22 1/2	60	51 3/8	5 7/8	18 5/8	51 5/8	5 5/32	27 1/4	4 3/4	57 1/4

* All measurements in inches.

SPECIFICATIONS PERFORMANCE Certified Air Delivery At 1" Increments Of External Static Pressure (Inches Static Pressure Water Gauge)

MAX B.H.P.	OPER. WGT.	AD MODEL BELT	AS MODEL BELT	0"		0.1"		0.2"		0.3"		0.4"		0.5"		0.6"		0.7"		0.8"		0.9"		1.0"	
				CFM	RPM	CFM	RPM	CFM	RPM	CFM	RPM	CFM	RPM	CFM	RPM	CFM	RPM	CFM	RPM	CFM	RPM	CFM	RPM	CFM	RPM
2	967	B90	B96	11375	303	10905	314	10482	324	10079	335	9678	346	9265	356	8830	368	8366	380	7867	394	7325	409	6753	426
3	980	B92	B100	13020	346	12604	356	12225	365	11865	375	11514	384	11165	393	10807	403	10440	413	10058	423	9651	433	9220	445
5	996	B93	B100	15438	410	15084	419	14749	427	14434	435	14133	443	13838	450	13540	458	13246	466	12899	474	12640	482	12328	490
7-1/2	1032	B95	B101	17672	470	17360	477	17060	484	16777	491	16505	498	16242	505	15983	512	15724	519	15463	526	15207	532	14947	539

Performance shown is for installation type B - Free inlet, Ducted outlet. Power rating (BHP) does not include drive losses. Models AS/AD 15012 include the affects of a 12 inch thick evaporative media on the inlet. When the Cooler Model No, Motor H.P., & Blower Speed are determined from the SPECIFICATION table above, use this information to select the proper pulley-belt kit from the SHEAVE SELECTION table below.

MOTOR SPECIFICATIONS

BLOWER MOTORS H.P.	SPEED	VOLTS	PHASE	MOTOR AMPS*	SHAFT DIA.	MOTOR WGT(LB)	MOTOR PART NO.	PUMP PART NO.	VOLTS	AMPS	WATTS	GPM (5 FT. HEAD)
2	1	208-230/460	3	7.5-6.8/3.4	7/8	44	110464-9	110468	230	0.58	77	4.6
3	1	208-230/460	3	10.6-9.6/4.8	1 1/8	83	110465-9	Pumps - 2 Required.				
5	1	208-230/460	3	16.7-15.2/7.6	1 1/8	87	110466-9					
7 1/2	1	208-230/460	3	24.2-22/11	1 3/8	121	110470-9					

* Amperage shown is from National Electrical Code. Use amperage shown on motor nameplate to determine motor protector.

SHEAVE SELECTION

MOTOR H.P.	MAUREY SHEAVE	SHEAVE BORE	AD MODEL BELT	AS MODEL BELT	BLOWER RPM/MOTOR SHEAVE 1/2 TURN DOWN											CHAMPION-AD PULLEY-BELT KIT NO.	CHAMPION-AS PULLEY-BELT KIT NO.	
					12	11	10	9	8	7	6	5	4	3	2			1
2	D8400	7/8	B90	B96	291	299	308	316	325	333	342	350	359	367	376	384	3DI-50	3DI-70
2	D8450	7/8	B90	B96	347	356	364	373	381	390	398	407	415	424	432	441	3DI-52	3DI-72
3	D8450	1 1/8	B92	B100	347	356	364	373	381	390	398	407	415	424	432	441	3DI-56	3DI-75
5	D8550	1 1/8	B93	B100	403	412	420	429	437	446	454	463	471	480	488	497	3DI-60	3DI-80
7-1/2	D8600	1 3/8	B95	B101	459	468	476	485	493	502	510	519	527	536	544	553	3DI-65	3DI-86

SIZING TABLES

OUTDOOR DRY BULB TEMP.	2 H.P. MOTOR / CFM-SP*			3 H.P. MOTOR / CFM-SP*			5 H.P. MOTOR / CFM-SP*			7-1/2 H.P. MOTOR / CFM-SP*		
	11375 / 0	9265 / .5	6753 / 1.0	13020 / 0	11165 / .5	9220 / 1.0	15438 / 0	13838 / .5	12328 / 1.0	17672 / 0	16242 / .5	14947 / 1.0
	OUTDOOR WET-BULB			OUTDOOR WET-BULB			OUTDOOR WET-BULB			OUTDOOR WET-BULB		
85	LAT	76 67 58	76 67 58	76 67 57	76 67 58	76 67 58	76 67 58	76 67 58	76 67 58	76 67 59	76 67 59	76 67 58
	GPH	12 25 37	10 20 30	8 15 23	14 28 42	12 24 36	10 20 30	16 33 49	15 30 45	13 27 40	17 33 50	17 35 52
95	LAT	77 68 59	77 68 59	77 67 58	77 68 59	77 68 59	77 68 59	77 68 60	77 68 59	77 68 59	77 69 60	77 68 60
	GPH	25 37 49	20 30 40	15 23 30	28 42 56	24 36 48	20 30 40	33 49 66	30 45 59	27 40 53	33 50 67	33 52 69
105	LAT	78 69 -	78 69 -	77 68 -	78 69 -	78 69 -	78 69 -	78 70 -	78 69 -	78 69 -	79 70 -	78 70 -
	GPH	37 49 -	30 40 -	23 30 -	42 56 -	36 48 -	30 40 -	49 66 -	45 59 -	40 53 -	50 67 -	52 69 -
115	LAT	79 70 -	79 70 -	78 69 -	79 70 -	79 70 -	79 70 -	80 71 -	79 70 -	79 70 -	80 71 -	80 71 -
	GPH	49 61 -	40 51 -	30 38 -	56 70 -	48 60 -	40 50 -	66 82 -	59 74 -	53 67 -	67 83 -	69 87 -

* Static Pressure (inches of water). GPH = Water consumption at design conditions but does not include bleed-off amount. Amount of bleed-off will vary with different water sources, but an amount equal to 10% of water consumption at any design condition is considered sufficient for average water. LAT = Cooler Discharge Temperature.

AS/AD 15012

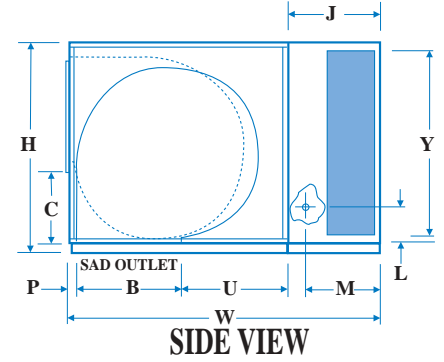
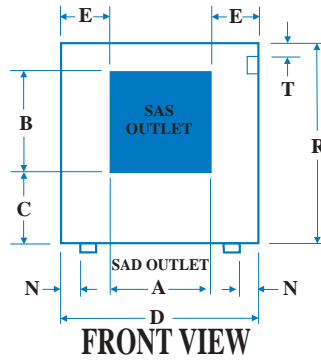
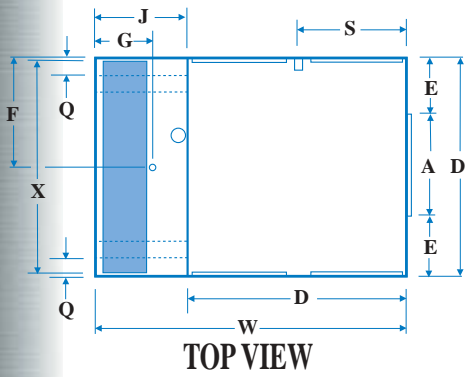

DIMENSIONAL DATA*

BLOWER MODEL NUMBER	WET MODULE NUMBER	CABINET			DUCT OPENING		DUCT LOCATION				DRAIN LOCATION		WET MODULE J	MEDIA DIMENSION		WATER SERVICE		ELECTRIC SERVICE		SKID LOCATIONS		
		H	W	D	A	B	C(SAS)	U(SAD)	P(SAD)	E	F	G		X	Y	L	M	S	T	N	Q	R
SAS/SAD 100B	100W	44	63 3/8	45	21 3/4	21 3/4	13 19/32	21 11/32	1 29/32	11 5/8	22 1/2	12 1/2	18 1/2	44 3/4	36 5/8	5 7/8	14 5/8	21 1/2	5 5/32	4 3/4	4 3/4	42
SAS/SAD 10012B	10012W	44	67 3/8	45	21 3/4	21 3/4	13 19/32	21 11/32	1 29/32	11 5/8	22 1/2	16 1/2	22 1/2	44 3/4	36 5/8	5 7/8	18 5/8	21 1/2	5 5/32	4 3/4	4 3/4	42
SAS/SAD 150B	150W	54	66 5/8	48 1/4	26 7/8	26 7/8	16 13/16	19 5/32	2 7/32	10 11/16	24 1/8	12 1/2	18 1/2	48	46 3/8	5 7/8	14 5/8	23 1/8	5 5/32	4 3/4	4 3/4	52
SAS/SAD 15012B	15012W	54	70 5/8	48 1/4	26 7/8	26 7/8	16 13/16	19 5/32	2 7/32	10 11/16	24 1/8	16 1/2	22 1/2	48	46 3/8	5 7/8	18 5/8	23 1/8	5 5/32	4 3/4	4 3/4	52

* All measurements in inches.

SPECIFICATIONS

PERFORMANCE Certified Air Delivery At .1" Increments Of External Static Pressure (Inches Static Pressure Water Gauge)

MAX B.H.P.	OPER. WGT.	SAD MODEL BELT	SAS MODEL BELT	0"		0.1"		0.2"		0.3"		0.4"		0.5"		0.6"		0.7"		0.8"		0.9"		1.0"	
				CFM	RPM	CFM	RPM	CFM	RPM	CFM	RPM	CFM	RPM	CFM	RPM	CFM	RPM	CFM	RPM	CFM	RPM	CFM	RPM	CFM	RPM
3/4	645	B90	B96	6997	267	6539	278	6087	289	5603	301	5051	315	4415	332	3717	353	3058	376	2497	398	2013	419	1571	436
1	649	B90	B96	7702	294	7286	303	6876	314	6450	324	5994	336	5477	349	4893	364	4260	383	3637	404	3085	425	2609	444
1 1/2	665	B90	B96	8817	336	8455	345	8091	353	7734	363	7359	372	6961	382	6525	393	6050	405	5527	419	4976	435	4425	453
2	669	B90	B96	N/A	N/A	9375	378	9044	386	8719	394	8389	402	8043	411	7683	420	7293	430	6869	440	6416	452	5932	465
3	681	B92	B100	N/A	N/A	N/A	N/A	N/A	N/A	N/A	N/A	N/A	N/A	N/A	N/A	9377	466	9070	474	8751	482	8407	490	8046	499

Performance shown is for installation type B - Free inlet, Ducted outlet. Power rating (BHP) does not include drive losses. Models SAS/SAD 15012 include the affects of a 12 inch thick evaporative media on the inlet. When the Cooler Model No, Motor H.P., & Blower Speed are determined from the SPECIFICATION table above, use this information to select the proper pulley-belt kit from the SHEAVE SELECTION table below.

MOTOR SPECIFICATIONS

BLOWER MOTORS							BLOWER MOTORS							PUMP PART NO.					
H.P.	SPEED	VOLTS	PHASE	MOTOR AMPS*	SHAFT DIA.	MOTOR WGT(LB)	MOTOR PART NO.	H.P.	SPEED	VOLTS	PHASE	MOTOR AMPS*	SHAFT DIA.	MOTOR WGT(LB)	MOTOR PART NO.	VOLTS	AMPS	WATTS	GPM (5 FT. HEAD)
3/4	1	115/208-230	1	13.8/7.6-6.9	5/8	24	110455	2	1	115/208-230	1	24/13.2-12	7/8	49	110460	115	1.0	73	4.6
3/4	2	230	1	6.9	5/8	29	110456	2	1	208-230/460	3	7.5-6.8/3.4	7/8	44	110464-9	230	0.58	77	4.6
3/4	1	208-230/460	3	3.5-3.2/1.6	5/8	20	110461	3	1	208-230/460	3	10.6-9.6/4.8	1 1/8	83	110465-9				
1	1	115/230	1	16/8	5/8	28	110457												
1	2	230	1	8	5/8	29	110458												
1	1	208-230/460	3	4.6-4.2/2.1	7/8	34	110462-9												
1 1/2	1	115/208-230	1	20/11-10	7/8	41	110459												
1 1/2	1	208-230/460	3	6.6-6/3	7/8	40	110463-9												

*Amperage shown is from National Electrical Code. Use amperage shown on motor nameplate to determine motor protector.

Pumps - 1 Required.

SHEAVE SELECTION

MOTOR H.P.	MAUREY SHEAVE	SHEAVE BORE	SAD MODEL BELT	SAS MODEL BELT	BLOWER RPM/MOTOR SHEAVE 1/2 TURN DOWN											CHAMPION-SAD PULLEY-BELT KIT NO.	CHAMPION-SAS PULLEY-BELT KIT NO.	
					12	11	10	9	8	7	6	5	4	3	2			1
3/4, 1	8350K	5/8*	B90	B96	253	261	269	278	287	296	304	313	321	330	338	347	3DI-130	3DI-165
3/4, 1	8450K	5/8*	B90	B96	347	356	364	373	381	390	398	407	415	424	432	441	3DI-135	3DI-170
1	8350	7/8*	B90	B96	253	261	269	278	287	296	304	313	321	330	338	347	3DI-140	3DI-175
1, 1 1/2, 2	8450K	7/8*	B90	B96	347	356	364	373	381	390	398	407	415	424	432	441	3DI-145	3DI-180
1 1/2, 2	8550	7/8	B90	B96	403	412	420	429	437	446	454	463	471	480	488	497	3DI-155	3DI-185
3	8550	1 1/8	B92	B100	403	412	420	429	437	446	454	463	471	480	488	497	3DI-161	3DI-190

*When selecting 1 H.P. motor, be sure to select Pulley-Belt Kit with same pulley bore as shaft size of motor selected.

SIZING TABLES

OUTDOOR DRY BULB TEMP.		3/4 H.P. MOTOR / CFM-SP*			1 H.P. MOTOR / CFM-SP*			1-1/2 H.P. MOTOR / CFM-SP*			2 H.P. MOTOR / CFM-SP*			3 H.P. MOTOR / CFM-SP*				
		6997 / 0 4415 / .5 1571 / 1.0			7702 / 0 5477 / .5 2609 / 1.0			8817 / 0 6961 / .5 4425 / 1.0			9375 / .1 8043 / .5 5932 / 1.0			9377 / .6 8046 / 1.0				
		OUTDOOR WET-BULB			OUTDOOR WET-BULB			OUTDOOR WET-BULB			OUTDOOR WET-BULB			OUTDOOR WET-BULB				
85	LAT	76 67 58	76 67 58	76 66 56	76 67 58	76 67 58	76 66 57	76 67 59	76 67 58	76 67 58	76 67 58	76 67 58	76 67 58	76 67 58	76 67 58	76 67 58	76 67 58	76 67 58
	GPH	8 15 23	4 9 13	2 4 5	8 16 25	6 12 18	3 6 9	9 19 28	7 15 22	5 10 15	10 20 30	9 17 26	6 13 19	10 20 30	9 17 26	10 20 30	9 17 26	10 20 30
95	LAT	77 68 59	77 68 59	76 66 56	77 68 60	77 68 59	76 67 58	77 69 60	77 68 59	77 68 59	77 68 59	77 68 59	77 68 59	77 68 59	77 68 59	77 68 59	77 68 59	77 68 59
	GPH	15 23 30	10 14 19	4 5 7	16 25 33	12 18 24	6 9 12	19 28 37	15 22 30	10 15 19	20 30 41	17 26 34	13 19 26	20 30 41	17 26 34	20 30 41	17 26 34	20 30 41
105	LAT	78 69 -	78 69 -	76 66 -	78 70 -	78 69 -	78 68 -	79 70 -	78 69 -	78 69 -	79 70 -	78 69 -	79 70 -	78 69 -	79 70 -	78 69 -	79 70 -	78 70 -
	GPH	23 30 -	14 19 -	5 7 -	25 33 -	18 24 -	9 12 -	28 37 -	22 30 -	15 19 -	30 41 -	26 34 -	19 26 -	30 41 -	26 34 -	30 41 -	26 34 -	30 41 -
115	LAT	79 70 -	79 70 -	76 67 -	80 71 -	79 70 -	78 68 -	80 71 -	79 70 -	79 70 -	80 71 -	80 71 -	79 70 -	80 71 -	79 70 -	80 71 -	80 71 -	80 71 -
	GPH	30 38 -	19 24 -	7 9 -	33 41 -	24 30 -	12 15 -	37 47 -	30 37 -	19 24 -	41 51 -	34 43 -	26 32 -	41 51 -	34 43 -	41 51 -	34 43 -	41 51 -

* Static Pressure (inches of water). GPH = Water consumption at design conditions but does not include bleed-off amount. Amount of bleed-off will vary with different water sources, but an amount equal to 10% of water consumption at any design condition is considered sufficient for average water. LAT = Cooler Discharge Temperature.

SAS/15012

CHAMPION COOLER certifies that the evaporative air coolers shown here are licensed to bear the AMCA Seal. The ratings shown are based on tests and procedures performed in accordance with AMCA Publication 211 and comply with the requirements of the Certified Ratings Program.



LIMITED WARRANTY

This warranty is extended to the original purchaser of an evaporative cooler installed and used under normal conditions. It does not cover damages incurred from accident, neglect, or abuse by the owner. Champion Cooler does not authorize any person or representative to assume for the Corporation any other or different liability in connection with this product.

TERMS & CONDITIONS OF WARRANTY

This warranty includes lifetime limited coverage on water reservoir against any leakage due to defects in material. From date of installation, if any original component part provided by Champion Cooler fails due to defect in material or factory workmanship only, Champion Cooler will provide the replacement parts as follows:

- Cabinet components for one year from date of installation
- Evaporative media for two years from date of installation

EXCLUSIONS TO THIS WARRANTY

- Champion Cooler is not responsible for any incidental or consequential damage resulting from any malfunction.
- Champion Cooler is not responsible for any damage received from the use of water softeners, chemicals, descaling material, plastic wrap, or if a motor of a higher horsepower than what is shown on the serial plate is used in the unit.
- Champion Cooler is not responsible for the cost of service calls to diagnose cause of trouble, or labor charge to repair and/or replace parts.

HOW TO OBTAIN SERVICE UNDER THIS WARRANTY

Contact the Dealer where you purchased the evaporative cooler. If for any reason you are not satisfied with the response from the Dealer, write or call: **Customer Service Department, Champion Cooler**, 5800 Murray Street, Little Rock, AR 72209, 501-562-1094, or e-mail Champion at: info@championcooler.com.

This limited warranty applies to the original purchaser only.



E & M Heating and Air Conditioning, Inc.
South Lipan Street Denver, Colorado. 80223
Telephone: (720) 377-0413 Facsimile: (720) 377-0472

CHAMPION • MARQUIS

Champion Cooler, 5800 Murray, Little Rock, AR 72209 800-643-8341 www.championcooler.com



Crafted With Pride In The USA

Catalog No. CSGB-January 2008